

ELEVATOR UNIVERSAL DOOR SPIRATORS

Elevator Door Spirators

Eliminate elevator door reel replacement problems with our spring-powered spirator. Pre-winding the reel upon installation allows universal replacement. Spring is made of high-carbon steel, the cable of 7 x 7 nylon coated galvanized steel with a crimped loop as opposed to eyelet. Each case is steel with Delrin arbors. Replaces Dover, Haughton, Montgomery, GAL, Otis, US, Westinghouse and Armor spirators.

Model ML-1880

Heavy-duty door spirator. Grey, 6" diameter steel reel with retracting cable. Cable is 144" long, 1/16" diameter, coated with nylon to diameter 3/32".

Model ML-4402

Zinc plated door spirator, 5" diameter steel reel with retracting cable pull. Cable is 120" long, 1/16" diameter, coated with nylon to diameter 3/32".

Model MLB

Square arbor mounting bracket for use with ML-1880 or ML-4402 spirators. Yellow zinc plated, 2-9/16" x 3-5/8" x 1/8" thick mounting plate, 5/16" square arbor 1-1/2" long.

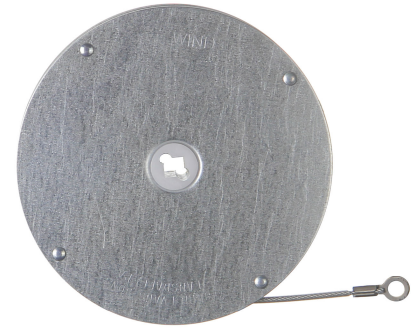

ML-4402



ML-1880

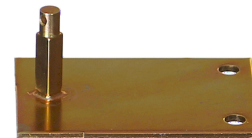

MLB

	Model ML-1880	Model ML-4402
Hub	Square Hole	Universal
Arbor Square	5/16" x 5/16"	5/16" x 5/16"
Arbor Dual Pin	N/A	2 x Ø13/64", distance 3/8" C/C
Drum Diameter (B)	5"	4-1/8"
Hub Diameter	3/4"	3/4"
Hub Depth (D)	1-7/64"	63/64"
Reel Diameter (A)	6"	5"
Reel Width (C)	15/16"	59/64"
Cable Length (E)	144"	120"

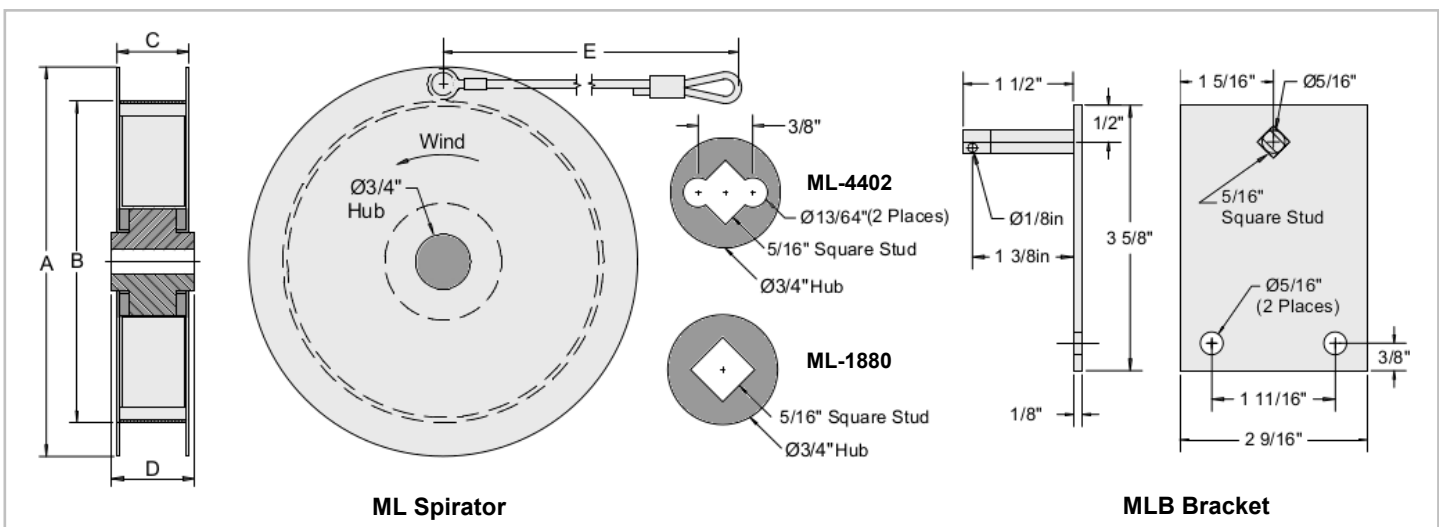

**QUALITY
ELEVATOR PRODUCTS, INC.**