



## BRUSHES VERIFICATION WORKSHEET

Name: \_\_\_\_\_ Reference #: \_\_\_\_\_

E-mail: \_\_\_\_\_ Phone: \_\_\_\_\_

Company: \_\_\_\_\_ Date: \_\_\_\_\_

Address: \_\_\_\_\_

### Data

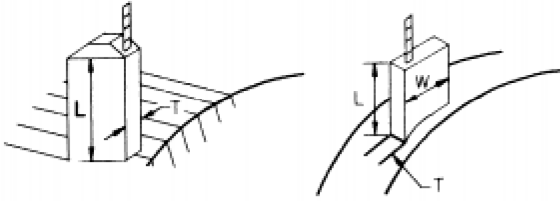
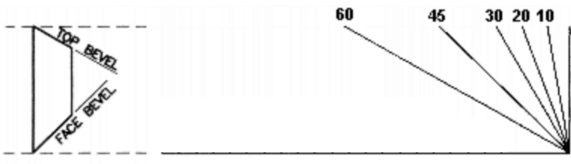
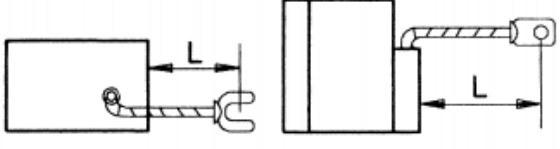
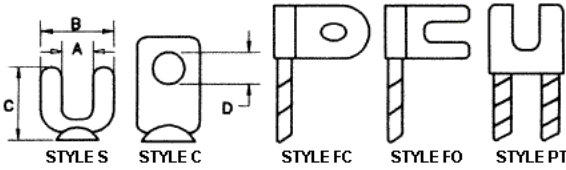
Equipment Manufacturer	_____	Brushes Per Unit	_____
It is a Hoist Motor (HP)	_____	Frame	_____
It is a Motor Generator (KW)	_____	RPM	_____
Brushes dimensions		Thickness	_____
		Width	_____
		Length	_____
Bevel angles		Top Bevel	_____
		Face Bevel	_____
Shunt length		Shunt Length	_____
Terminal		Dimensions A	_____
		B	_____
		C	_____
		D	_____

### Notes

\_\_\_\_\_

\_\_\_\_\_

\_\_\_\_\_

BVWS052215

Please fill out the form and e-mail it to [sales@qualityelev.com](mailto:sales@qualityelev.com) or fax it to 847-581-0095.

© Quality Elevator Products, Inc. • 800-222-3688 • 7760 N. Merrimac Ave. Niles, IL 60714 • [www.qualityelev.com](http://www.qualityelev.com)