

# TOP OF CAR HANDRAIL

*Stay Safe With Quality*

- Features:**
- Designed to comply with ASME A17.1a-2004
  - Quick and easy installation
  - Made from 1-7/8" and 1-5/8" square 12 Ga. galvanized telescoping channels
  - Channel holes 9/16" Dia, punched in regular 1-7/8" intervals
  - L-shaped 4"x2" galvanized toe guard and intermediate channels included
  - Weight 3.6 lb. per linear foot

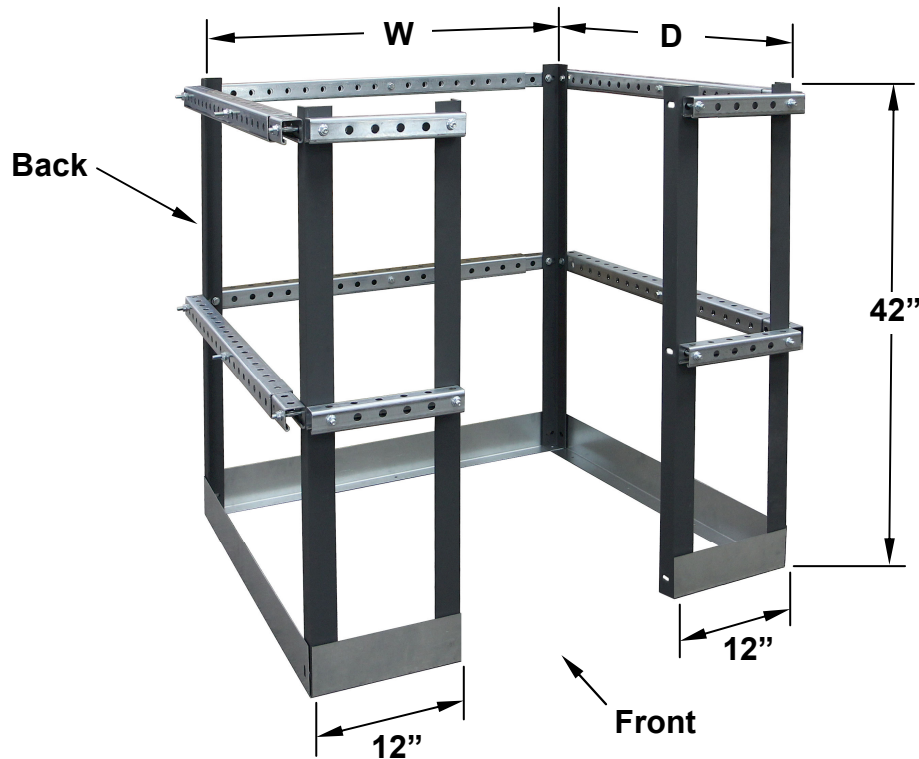

**Model TOCH-72** 60"W x 60"D x 42"H with Front opening shown

- Custom Order Information:**
- Only Front opening
  - Front and Back opening
  - Handrail depth (D") \_\_\_\_\_
  - Handrail width (W") \_\_\_\_\_

**QUALITY  
ELEVATOR PRODUCTS, INC.**

TOCH\_011922

Quality Elevator Products, Inc. • 7760 Merrimac Ave. Niles IL 60714 • Phone: (847) 581-0085 • Fax: (847) 581-0095 • www.qualityelev.com